

DIAMETER SIZE	TOOL #
.070	B-595
.089	B-287
.101	B-289
.109	B-288
.111	B-290
.120	B-283
.124	B-493
.125	B-291
.127	B-492
.130	B-292
.132	B-284
.136	B-293
.140	B-285
.141	B-286
.145	B-583
.159	B-294
.166	B-655
.171	B-601
.178	B-295
.200	B-296

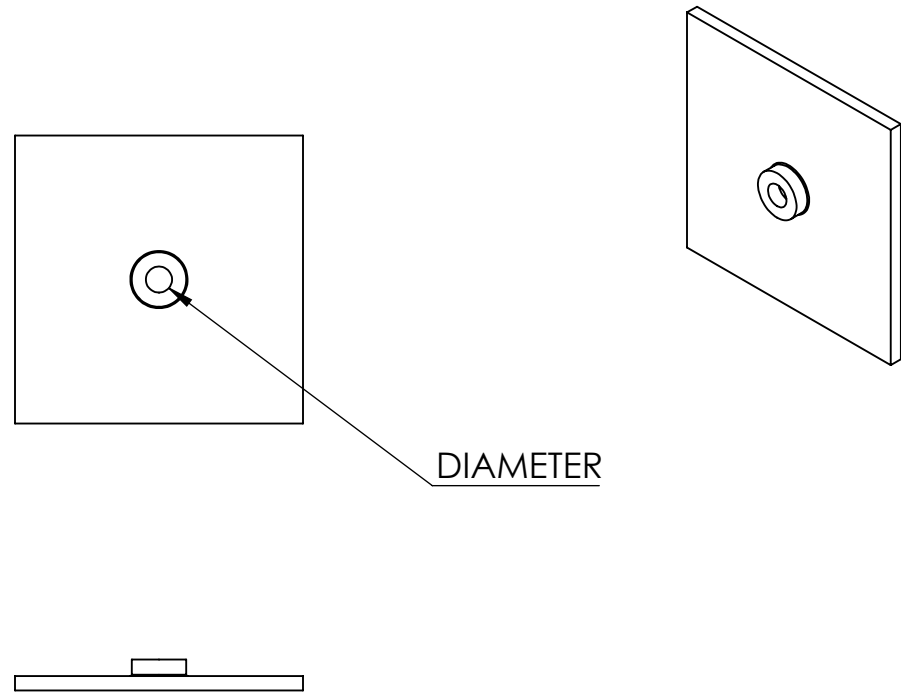

NOTES:

1. EXTRUSION HEIGHT VARIES BY MATERIAL THICKNESS.
2. MAX MATERIAL THICKNESS IS .080.
3. CNC TAPPING OF EXTRUSIONS REQUIRES ROLL TAP DIAMETER.

Courtesy of  
Data Metalcraft, Inc.  
RESOURCE CENTER  
[www.datametal.com](http://www.datametal.com)

**DATA**  
**METALCRAFT**  
**INC.**

**PROPRIETARY AND CONFIDENTIAL**

THE INFORMATION CONTAINED IN THIS DRAWING IS THE SOLE PROPERTY OF DATA METALCRAFT INC. ANY REPRODUCTION IN PART OR AS A WHOLE WITHOUT THE WRITTEN PERMISSION OF DATA METALCRAFT INC. IS PROHIBITED.

CATEGORY:

SIZE	TITLE:	REV
<b>A</b>	<b>EXTRUSION</b>	<b>A</b>

DO NOT SCALE DRAWING    SCALE: 5:1    SHEET: 1 OF 1